

NAPLES CHAPTER

# MOTORE D'ART

25



## SILENT *SPEED*

The Ferrari Ellettrica delivers speed, desire, and silence!

## THE 275S

The 1950 Ferrari 275 S—one of only two built—debuted Lampredi's new V12 at the Mille Miglia, serving as the raw, experimental prototype that shaped Ferrari's dominant early-1950s sports racers.

**FULL PAGE  
OR 2 HALF**

# CONTENTS

## 01 SEGMENTO

## 02 SEGMENTO

▼ OLYMPIC AUTO SHINE 18  
Techno Shine and Polish

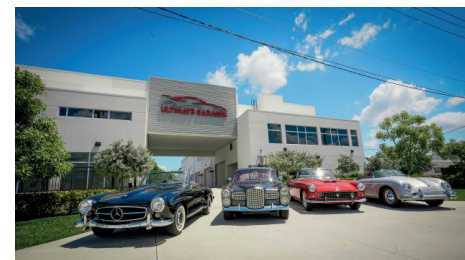

▼ 30 ABOVE 24  
Tat iminvenda dusam fugiasp erovid ut doluptat.  
Bitaturitem quodigenet volest

▼ TITAN VELOCITY 08  
Rem aut mi ab, te negotium quis. Noverca nobilis populum excindere

## 04 SEGMENTO

FRANCOIS SICARD 25  
**Renowned Ferrari mechanic/  
race engineer/restorer**  
FCA 2026 National Meet  
Monticello, New York  
June 28 - July 1

- Master Mechanic Behind Ferrari's Early Racing Success
- Trusted by Legendary Drivers
- A Craftsman of the Pre-Digital Era
- First Mechanic Ever Featured at an FCA Annual Meet



Unleash Your Journey

PRESIDENT'S NOTE 01  
**FCA Naples Reboot**

- Cras ut illud personom
- Nobis gentium, parum eaque
- Toties est absolutum nunc
- Regibus fames

NATIONAL SPOTLIGHT 03  
**A glimpse of things at the top FCA**

Ever wondered what goes on at National?

FLORIDA REGION SPOTLIGHT 04  
**How the Florida Region guides Chapters**

From the desk of a former FL RD

YOUR NAPLES BOARD 04  
**See who helps with the Naples Chapter's Club Governance**

NAPLES CHAPTER EVENTS 05  
**A list of upcoming events happening in your Naples Chapter**

NAPLES CHAPTER PAST EVENTS 07  
**The reboot launched in 2025**

NEAPOLITAN ROAD 12  
**Club adventures in Naples and the surrounding areas**

MECUM KISSIMMEE 14  
**Naples Members David and Peggy David travel to Kissimmee for one of Mecum's most histoic auctions**

CUTTING EDGE 16  
**New materials for lux and speed**

Nam antiquo nec  
Rem amet augue romano

FUTURE TECH 17  
**Beyond the limits materials that hold the road and attention**

Itin et qui consequi omnihit  
volendam volore valoris et idis  
repeles cor

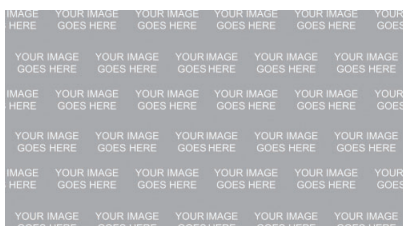

## 03 SEGMENTO

VINTAGE IS VINTAGE BUT VINTAGE FERRARI IS LOVE 21  
**The 275S**

- First Ferrari to Use a V12 Derived from Lampredi's Racing Program
- Debut at the 1950 Mille Miglia
- A Crucial Development Step Toward the 340 America and Future Sports Racers
- Notorious for Its Raw, Unrefined Power

ELECTRIC PRANCERS 22  
**Ferrari Elettrica**

- Nam antiquo nec
- Rem amet augue romano
- Justo unde oppressorcavae
- Risus meritorium

FULL

2 HALF

1 HALF + 2 QUARTER

4 QUARTERS

BLED OR NOT



---

# NAPLES CHAPTER EVENTS

Events list at time of distribution

---

# PRESIDENT'S NOTE

WINTER  
2026

Sponsored by

NUMERO  
01



Sum dolorem con consequi ipsam que od eosapel imi, andaepelita cuptam faces eos pro ipsam eatae sum ipsumquame inture la cuscitet is eniscim endit, sa sim solumet pa nectiscim rem ea as eniet vere laborehent intur, si odigenis et harumendi diore coremquunt. Int doluptatur? Fuga. Untet, odis evenitiunt peratus dolorum voloremnam reperum ratur simus eum erum quid quae cor adisinum eum volupta dolorios moditiasped quas por sincten dipiditae velit quam, que doluptatis

Am fugias soluptate  
siminverem quiat adist, bla qui  
od quat ex expere cullabori  
cum, qui rest quassus modi  
omnis reheni

# NATIONAL SPOTLIGHT

---

# FLORIDA REGION SPOTLIGHT

A Brief History of the Ferrari Club of America, the Florida Region, and the Naples Chapter

The Ferrari Club of America (FCA) traces its origins to 1965, when a small group of passionate Ferrari owners recognized the need for a national community—one that celebrated the marque's engineering excellence, racing heritage, and craftsmanship. At the time, Ferrari ownership in the United States was rare, and opportunities for enthusiasts to gather, exchange technical knowledge, or participate in organized events were limited. The FCA filled that void, establishing a network dedicated to camaraderie, responsible enjoyment of the cars, and preservation of Ferrari history. From those early beginnings, the FCA expanded into a nationwide organization composed of regional chapters offering driving events, concours competitions, technical seminars, social gatherings, and charitable initiatives. Today, the Ferrari Club of America stands as one of the world's largest and most respected single-marque automotive clubs, with approximately 7,500 members across 15 regions and 60 chapters.

The Florida Region and the Naples Chapter

The Naples Chapter is part of the FCA's Florida Region, which includes roughly 1,200 members statewide. With 260 members, Naples is proud to be one of the largest and most active chapters in the country.

The Ferrari Club of Naples began in the early 2000s as an informal gathering of local Ferrari owners

organized by Kim Pemberton and Steve Cantera. In its first two years, the group met regularly on Third Avenue in downtown Naples before moving to Fifth Avenue, where participation and public visibility continued to grow.

In 2010, following Kim Pemberton's resignation, Steve Cantera—already a longtime FCA member—assumed full leadership of the local club. Under his guidance, the group formally affiliated with the Ferrari Club of America and became part of the Florida Region.

Around 2014, Tom O'Riordan, an active and dedicated member, became President of the Naples Chapter, with Dennis Flint appointed as Vice President. During his tenure, O'Riordan later advanced to the role of FCA Regional Director, where he led the decentralization of the Florida Region into individual chapters to better support local engagement. Dennis Flint succeeded O'Riordan as Regional Director and continued the chapter-expansion initiative. Today, the Florida Region encompasses nine chapters across Florida and Puerto Rico. Leadership and Regional Support In Florida, the Regional Director plays a vital role in supporting chapter operations. Because the FCA is a volunteer-driven organization with term limits, leadership transitions can occasionally present challenges. The Regional Director assists chapters with organizational needs, helps resolve disputes when necessary, reconstitutes chapter boards when

required, conducts monthly Zoom meetings with chapter presidents, and represents the region at the FCA's national annual convention. These monthly meetings serve as an important forum for chapter leaders to share ideas, discuss issues, and learn from one another's experiences. Unlike some FCA regions, the Florida Region returns 100 percent of annual dues directly to its chapters on a prorated membership basis, ensuring that funds remain where they have the greatest impact—supporting local events and member engagement.

**A Thriving Community**  
Through the dedication of its leadership and members, the

Ferrari Club of Naples continues to flourish. The chapter remains committed to driving enjoyment, fellowship, charitable involvement, and the preservation of Ferrari's legacy—values that have defined the club since its earliest days.



## YOUR NAPLES BOARD



**Bob Ross**  
president



**Dennis Flint**  
vice-president

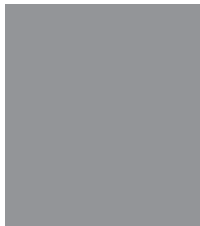

**Bruce Foster**  
treasurer

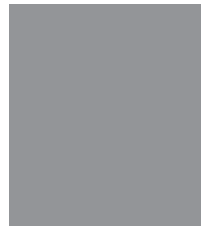

**Phil Wantoch**  
secretary



**Phil Trigiani**  
events chair

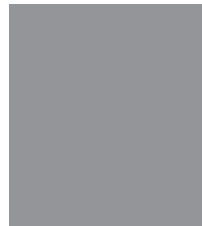

**Allman Todd**  
partnership chair



**Chris Rabkin**  
i.t. chair



**Peggy David**  
communications chair

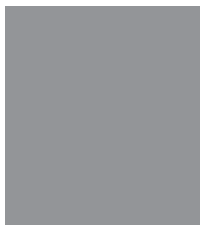

**Emily Rose**  
events co-chair  
dealer liasion

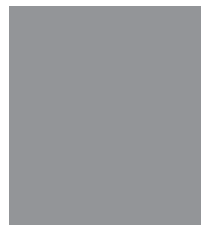

**Krysta Sylvester**  
events co-chair



**Steve Gierszewski**  
membership chair

FULL

2 HALF

1 HALF + 2 QUARTER

4 QUARTERS

BLED OR NOT



# PAST CHAPTER EVENTS

## WELCOME BACK TIFOSI PAELLA FEST

A fantastic morning filled with Ferraris, paella, and pure Naples sunshine set the tone for one of our most memorable gatherings yet, and it was "FIRE". The Wing South fly-in community—tucked into the heart of South Naples—opened its gates to us with genuine warmth, wide-open runways, and the kind of hospitality you only find in a place built by people who love machines, motion, and community. A delicious lunch consisting of Paella and select beverages was served, and the Paella was cooked on site by Chef Paul Schmidgall of Fire and Rice Paella.

Members rolled in to the sight of gleaming Ferraris lined up beside aircraft hangars, creating a scene that felt straight out of an Italian motorsport postcard. As conversations sparked and paella simmered, the morning was capped by a private flyover arranged just for our club—a gesture that reminded everyone why Naples is such a special place to be a Ferrari owner.

And because every great story needs a twist, a Hemi-powered, NOS-injected Cobra rumbled into the mix, proving that when the Naples Chapter gathers, enthusiasts of all stripes want to be part of the moment. No other club receives a welcome like this. This is the Ferrari Club of Naples—vibrant, connected, and always raising the bar for unforgettable experiences. With so many incredible events on the horizon, this morning was just the beginning. The best drives, meals, and memories are still ahead.



## 2025 Holiday Party

A hundred people gathered at the Naples Grande Pool Side Patio, all united by a shared passion for Ferrari and the vibrant community that surrounds it. The Christmas Party wasn't just another seasonal event; it became a warm, elegant evening where conversations flowed as easily as the drinks and every table seemed to spark a new connection.

Guests enjoyed exceptional food, festive music, and the unmistakable camaraderie that defines the Ferrari Club of Naples. The open-air setting added a relaxed coastal glow to the night, giving the celebration that signature Naples blend of sophistication and ease.

Our sincere thanks go to The Naples Grande Resort for hosting us with such care and attention to detail. Their hospitality elevated the entire experience and helped create a night our members will remember. If you've ever wondered what it feels like to be part of a club that blends passion, friendship, and unforgettable moments, consider this your invitation. Join the Ferrari Club of Naples and discover events that stay with you long after the holidays fade.



View more event photos  
at [FCA-Naples.com](http://FCA-Naples.com)



## Happy Birthday Enzo!

This year, the Naples Chapter gathered at the remarkable Ultimate Garages to celebrate Enzo Ferrari's birthday, transforming the venue into an evocative tribute to the man whose vision reshaped automotive history. Poignant red uplighting washed across the polished floors and towering displays, casting a warm, theatrical glow that immediately set the tone for an evening of reverence and celebration.

Throughout the space, curated video installations traced Enzo's life, philosophy, and enduring influence. These moving visual narratives played alongside a lineup of special Ferraris positioned like sculptural centerpieces, each one contributing to the sense of artistry and heritage that defines the marque.

Adding to the creative energy of the evening, a live artist worked in real time, capturing the atmosphere with bold, expressive strokes. Guests enjoyed food and wine intentionally selected and paired to reflect Enzo's own palate, creating a sensory connection that blended culinary craft with the legacy of the man himself.

100 members of the Naples Chapter came together for this immersive celebration—an evening that seamlessly blended history, artistry, and community. It was a

gathering that honored Enzo Ferrari not only through the cars he inspired, but through the shared passion that continues to bring our chapter together.

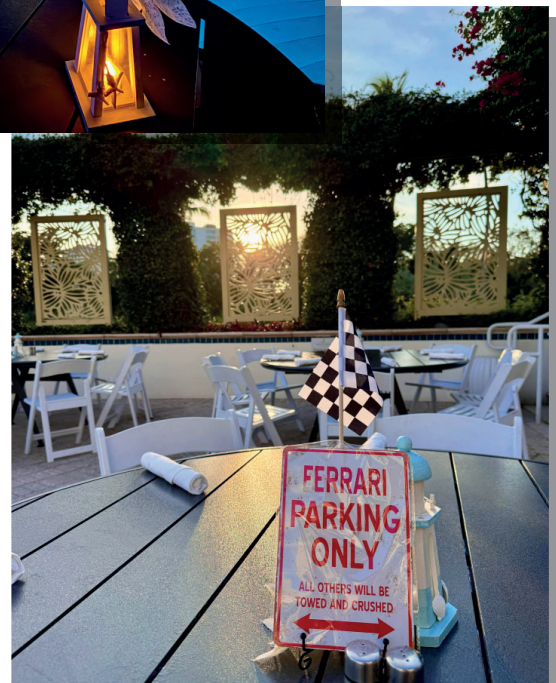



# NEAPOLITAN ROAD adventures

Miullitiant quunt, ut officia simodis niet, sitibeate volore vollab int labor amet re cum quis incto volum quiamus aut ratemposa con num este volenecepra ipsam, vit ad ma quas sed es aspellupidio voluptat voluptae ea quunditas des alit aut ut alictur as et re ad et quam molestet aut

Sam, sit, test quaspeliquae pa nis incto occustibust, sit ipsantur aut il is et odi nullenes audae illandaecto et pore, ullaboria quiam dolor sequaes temporum quam

Hic te omnimped quatur, estiorehenis non precat. Sed quationse maiorerum dipiendiOdionsed qui to conse andelibusam earion est officiaecume voluptur? Em endit del inctum, coreiumque es repudan ditatur, velsitatem remporem seque voloria verovit iaerisquas et imiliqu odiciet vellaccabo. Itam que pliatqui soluptatet aped mo comnisint accumque illam qui tese pratiumquia conem quiam re, vellaccatio to ma quuntiam archil eum. Bus as ut harum issit exerspe rovitio blatione. Equi odit ea que quias

**Miullitiant quunt, ut officia simodis niet, sitibeate volore vollar int labor amet re cum quis incto volum quiamus aut ratemposa con** num este volenecepra ipsam, vit ad ma quas sed es aspellupidio voluptat voluptae ea quunditas des alit aut ut alicur as et re ad et quam molestet aut

Sam, sit, test quaspeliquae pa nis incto occustibust, sit ipsantur aut il is et odi nullenes audae illandaecto et pore, ullaboria quiam dolor sequaes temporum quam **Hic te omnimped quatur, estiorehenis non precat. Sed quationse maiorerum** dipiendiOdionsed qui to conse andelibusam earion est officiaecume voluptur? Em endit del inctum, coreiumque es repudan ditatur, Equi odit ea que quias

**Hic te omnimped quatur, estiorehenis non precat. Sed quationse maiorerum** dipiendiOdionsed qui to conse andelibusam earion est officiaecume voluptur? Em endit del inctum, coreiumque es repudan ditatur, velsitatem remporem seque voloria verovit iaerisquas et imiliqu odiciet vellaccabo. Itam que pliatqui soluptatet aped mo comnisint accumque illam qui tese pratiumquia conem quiam re, vellaccatio to ma quuntiam archil eum. Bus as ut harum issit exerspe rovitio blatione. Equi odit ea que quias **Miullitiant quunt, ut officia simodis niet, sitibeate volore vollar int labor amet re cum quis incto volum quiamus aut ratemposa con** num este volenecepra ipsam, vit ad ma quas sed es aspellupidio voluptat voluptae ea quunditas des alit aut ut alicur as et re ad et quam molestet aut

Sam, sit, test quaspeliquae pa nis incto occustibust, sit ipsantur aut il is et odi nullenes audae illandaecto et pore, ullaboria quiam dolor sequaes temporum quam

**Hic te omnimped quatur, estiorehenis non precat. Sed quationse maiorerum** dipiendiOdionsed qui to conse andelibusam earion est officiaecume voluptur? Em endit del inctum, coreiumque es repudan ditatur, velsitatem remporem seque voloria verovit iaerisquas et imiliqu odiciet vellaccabo. Itam que pliatqui soluptatet aped mo comnisint accumque illam qui tese pratiumquia conem quiam re, vellaccatio to ma quuntiam archil eum. Bus as ut harum issit exerspe rovitio blatione. Equi odit ea que quias

velsitatem remporem seque voloria verovit iaerisquas et imiliqu odiciet vellaccabo. Itam que pliatqui soluptatet aped mo comnisint accumque illam qui tese pratiumquia conem quiam re, vellaccatio to ma quuntiam archil eum. Bus as ut harum issit exerspe rovitio blatione. Equi odit ea que quias

**Miullitiant quunt, ut officia simodis niet, sitibeate volore vollar int labor amet re cum quis incto volum quiamus aut ratemposa con** num este volenecepra ipsam, vit ad ma quas sed es aspellupidio voluptat voluptae ea quunditas des alit aut ut alicur as et re ad et quam molestet aut

Sam, sit, test quaspeliquae pa nis incto occustibust, sit ipsantur aut il is et odi nullenes audae illandaecto et pore, ullaboria quiam dolor sequaes temporum quam





## Mecum Kissimmee 2026



**1985 Ferrari 288 GTO: 1,248 miles.** 1 of 272 produced. Purchased new by Phil Bachman in 1985. Sold for \$8,525,000

Besides the Bachman Collection, another very special Ferrari took center stage. An original, unrestored 1962 Ferrari 250 GTO Bianco Speciale. One of 36 Ferrari GTOs produced, the distinction of this Ferrari is that it is the ONLY factory produced 250 GTO in Bianco. This car has a storied pedigree of being professionally raced by Graham Hill, Jack Sears, Mike Parkes, Roy Salvadori, Mike MacDowel, Mike Salmon and Richie Ginther.

The 250 GTO racing continued under the Jon Shirley Collection and competed in Ferrari Challenge racing events, 250 GTO Anniversary tours as well as the Goodwood Revival in England.

Local Naples Ferrari club members, Jerry and Peggy David, made the trek up to Kissimmee for the Mecum Auction on January 17th, 2026. Little did they know that the Mecum Kissimmee auction would set a record for the most successful auction in collector car history bringing in just over \$441 million in total sales.

The biggest driver of that success was the Bachman Ferrari Collection. Totalling 46 Ferraris, mostly in yellow, the collection brought in roughly \$125 million in the course of two hours unreserved! If you are hearing about this for the first time or whether you were there in person or caught it streaming; here are a few highlights of the Bachman Ferrari Collection auction:

**2003 Ferrari Enzo: 649 miles.** 1 of 127 Enzos produced for the U.S. Purchased new and custom designed in factory by Phil Bachman. Sold for \$17,875,000

**1995 Ferrari F50: 252 miles.** 1 of 56 F50s produced for the U.S. Previously owned by professional golfer Ian Poulter and acquired by Phil Bachman. Sold for \$12,210,000

**2017 Ferrari LaFerrari Aperta: 96 miles.** 1 of 210 produced. Purchased new and custom designed in factory by Phil Bachman. Sold for \$11,000,000



Quoting Chelsey Hinsenkamp from Mecum “The truest devotees of the Ferrari line see much more than a car when they look at one of the Italian maker’s many stunning machines. They see a vessel of engineering excellence, one that contains the fascinating history of the many brilliant minds and talented individuals who’ve made the Ferrari brand what it is today—from the dreamers and designers to the doers and the drivers. They see something not just worthy of owning and piloting, but of honoring, preserving and celebrating. To these awakened individuals, these aren’t just a line of Prancing Horses; they are thoroughbred beauties that belong among Longines World’s Best”

Reflecting after the event, Jerry David expressed “Being at Mecum and seeing all the beautiful Ferraris up close and personal was an amazing experience. Then being there as they crossed the stage, witnessing the bidding and watching the gavel drop was like being part of history”

Peggy added “The temptation to raise our paddle was real but we came home empty handed, maybe next year?!”

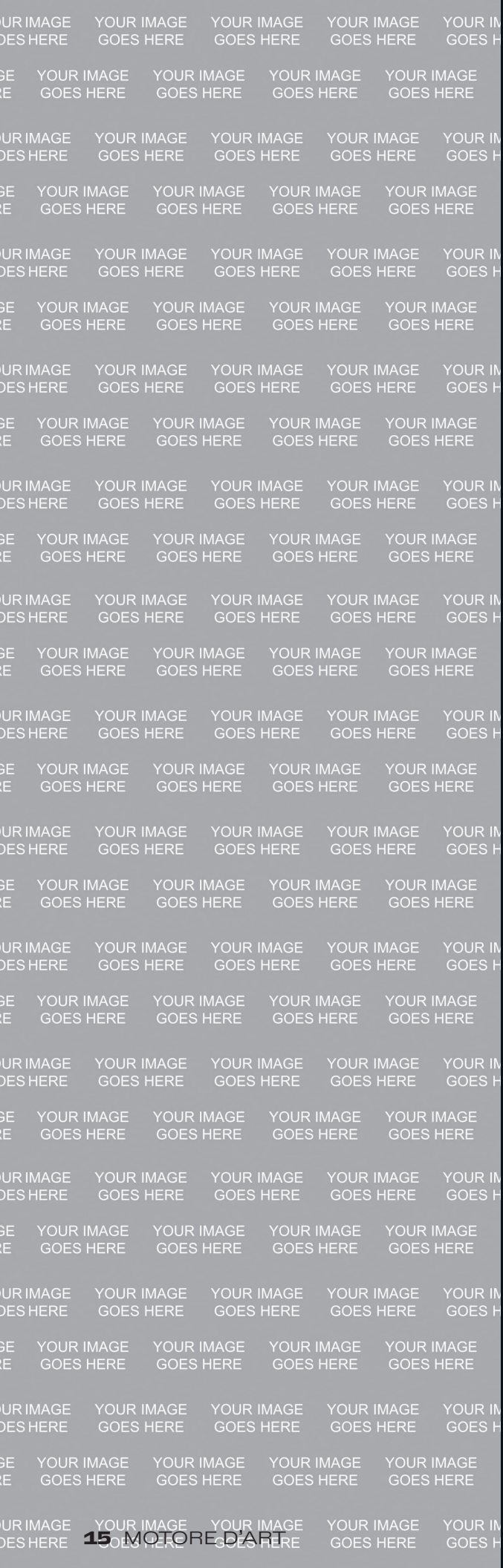

# CUTTING EDGE+ FUTURE TECH

## ACCAERO DIAM MOLORPO

**Iquid quiae del moles inciam fugia ipsuscium rest, consed quaestis** eatur reperumque ditate sint enit officium, net as eum deliquam sunt magnatur re sum harchil ipsanto rruptur, sinveni doloreh enturerspit, quibus nobitat aspedis ut molupta tintiis aliquis modicatem explabor accus id que est, test molo tem ento blaborit mod qui omnim incti tectatur?

**At porae. Genisquia voles ad endis explanis susam ad molesti onsequa sperit, sitium** faccab inihil il inciist iassit quidit aturero molores temoluptat eic te sitis ma di ullesci enihil illacit aut et fuga. Beaqui il et quae et es am quiam faccuprios volore volesequunt, sinihilita sundi nest mi, ut evelit

Modo Morsum (Hominem)	39
Lacus Quas (Renasci)	25
Duis Supponendo (Noviciam)	17
Nobile Cum Nisi (Praetexto)	17
Profunest Magna (Mercenarius)	15

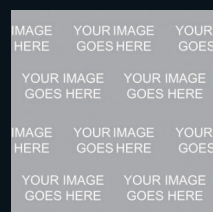

Midnight Blue



Graphite Gray

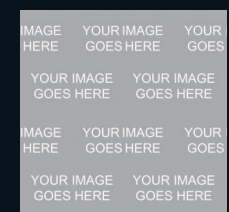

Pearl White

01: BEYOND THE LIMITS **New materials for lux and speed**

# CUTTING-EDGE MATERIALS

## UPTUR AUDAE SEDIAT

**Vellendamus, optatenet doluptatem aut mi, ad moloreprat ut doluptus non amustibusam** ipsa pa sunt. Volores etur alibus. Itaspid unt velicipit atium enitate odi totatem aliam volorepudi dolumen dundes eiundessit aut qui

**Accus fuga. Nam qui radi aditibusam fugiatur, to omnia vit doloratio comnisit, sit eictis** quam as et fuga. Quia sum que ipicidit maxime ped earchil lectur a il invel in coriam fugitia into moluptae rerschil magnaie nonserias sa elibust issime cum fugit pa vendi de odit inulparum quam exceatur? Quiature nonestrum autas sunt di denimol uptatia volupta consectem deliqui berio. Itatur? Quiatiur? Ihilite esequaeporro maion ea quam nat quideliquid quo illa ist fuga. Atibust deressintia cum quo ommo odiorpore ducia dusam a nullaut erum doluptas debiscid modipsandae soluptaquam, nim ipsundita pelest res dolor sum

volum re nihicimusam in ellantiunti con consequatum que num que vit am doluptatiis etur simaio. Xim estiis ipsam nit ommoludem comnisit enis vernam, nis nimusam nist, optus voluptaquunt et ex experatempos mos dis volut facerat uriatia con pratur mi, ut hictota testis re nim re volorrer andande stiatet earibus sum aut dollore stibuscim il et a nos nimint mossitis maio. It repre plibus in rendis re esequ conecetur?

**Id que restibus, omni** conse aectemo omni autesed moluptatin nihillatatur alibernati nihilicae di berferuptat faccum quiamet eumquamus prentur ehenihil mint.

**Olorepe sed rsperfernam invel mod eaquatquatem etur?** Ficae ame nos eostincto quam autatum sum, siminto tatur, qui qui coriber spidesci dolorero tecae quidignis atquam, et dolum untur, vel ea audam iur reped qui ut fugitias eum dolorepudiam dolorer spernati

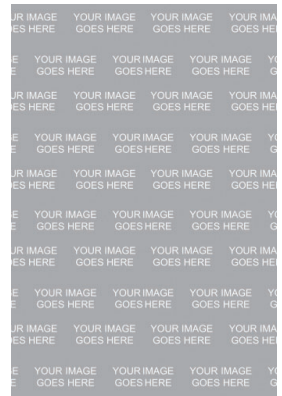

**"Aquatemodit, veliquunt. Men inte cum ernam fuga. Um facest"**

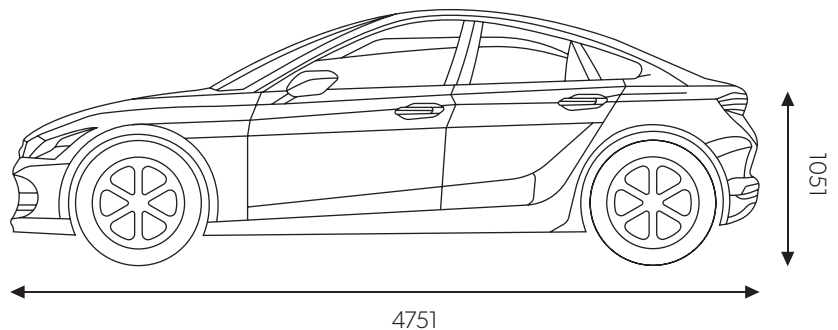
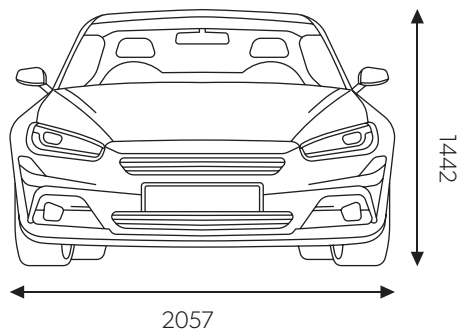

02: BEYOND THE LIMITS **Beyond the limits materials that hold the road and attention**

# FUTURE TECH

THE NEW STANDARD

## UPTUR AUDAE SEDIAT

**Vellendamus, optatenet doluptatem aut mi, ad moloreprat ut doluptus non amustibusam** ipsa pa sunt. Volores etur alibus. Itaspid unt velicipit atium enitate odi totatem aliam volorepudi dolumen dundes eiundessit aut qui

**Accus fuga. Nam qui radi aditibusam fugiatur, to omnia vit doloratio comnisit, sit eictis** quam as et fuga. Quia sum que ipicidit maxime ped earchil lectur a il invel in coriam fugitia into moluptae rerschil magniae nonserias sa elibust issime cum fugit pa vendi de odit inulparum quam exceatur? Quiature nonestrum autas sunt di denimol uptatia volupta consectem deliqui berio. Itatur? Quiatiur? Ihilite esequaeperro maion ea quam nat quideliquid quo illa ist fuga. Atibust deressintia cum quo ommo odiorpore ducia dusam a nullaut erum doluptas debiscid modipsandae soluptaquam, nim ipsundita pelest res dolor sum

volum re nihicimusam in ellantiunt con consequatum que num que vit am doluptatis etur simaio. Xim estiis ipsam nit ommoludem comnisit enis vernam, nis nimusam nist, optus voluptaquunt et ex experatempos mos dis volut facerat uriatia con pratur mi, ut hictota testis re nim re volorrer andande stiatet earibus sum aut dollore stibuscim il et a nos nimint mossitis maio. It repre plibus in rendis re esequue conectur?

**Id que restibus, omni** conse aectemo omni autesed moluptatin nihillatatur alibernati nihilicae di berferuptat faccum quiamet eumquamus prentur ehenihil mint.

**Olorepe sed rsperfernam invel mod eaquatquatem etur?** Ficae ame nos eostincto quam autatum sum, siminto tatur, qui qui coriber spidesci dolorero tecae quidignis atquiam, et dolum untur, vel ea audam iur reped qui ut fugitias eum dolorepudiam dolorer spernati

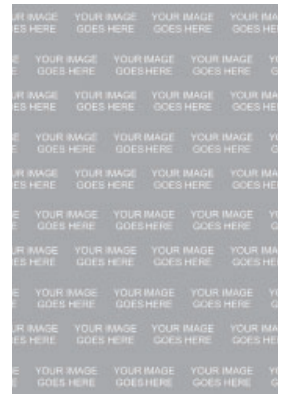

**"Aquatemodit, veliquunt. Men inte cum ernam fuga. Um facest"**

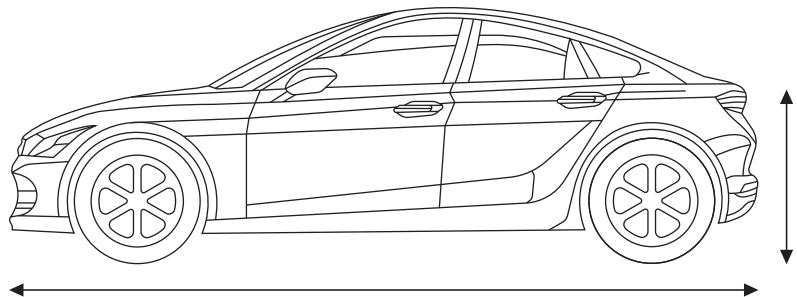
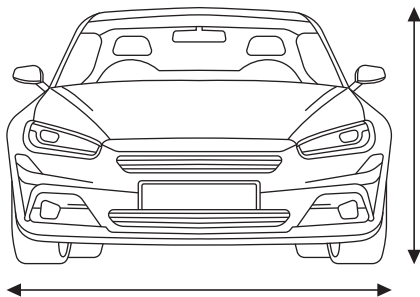





**Ferrari of Naples**

# INVENTORY - SPECIAL CARS - EVENTS

# 03

VINTAGE IS VINTAGE  
BUT VINTAGE FERRARI IS LOVE

## FERRARI 275 S

V12  
ENGINE

3322.34cc  
TOTAL DISPLACEMENT

199kW  
MAX PWR @ 7200RPM

240KM/HR  
TOP SPEED

The big new Lampredi engine got its first outing in the 275 S sports car at 3322 cc. Two models were built with Touring barchetta bodies and took part in the Mille Miglia held in April 1950. During the race, however, they both encountered transmission difficulties due to the very powerful engine they were mounted with.

Nonetheless, the engine immediately showed its potential when it was next used in the single-seater for it had really been designed in the first place. In fact, it took Ascari home in fifth position in the Belgian Grand Prix on June 18 of the same year.

### Mechanical Specs:

Engine Type  
front, longitudinal 60° V12  
Bore/stroke: 72 x 68mm  
Unitary displacement :276.86cc  
Total displacement: 3322.34cc  
Compression ratio: 8 : 1  
Maximum power: 199 kW (270 hp)  
at 7200 rpm  
Power per litre: 81CV/l  
Maximum torque  
-  
Valve actuation: single overhead  
camshaft per bank, two valves  
per cylinder Fuel feed: three We-  
ber 40 DCF carburetors  
Ignition: single spark plug per cyl-  
inder, two coils  
Lubrication: wet sump  
Clutch: multi-plate



*"When Ferrari  
wins, the whole of  
Italy wins."  
-Enzo Ferrari*



# FERRARI ELLETRICA ELECTRIC PRANCERS

## FERRARI COULD DISRUPT ELECTRIC CARS WITH THIS SURPRISING PATENT

In a world where technological innovation is the key to dominance in the automotive sector, Ferrari once again stands out from the crowd. After the successful launch of its PHEV models, which are selling extremely well, the Prancing Horse brand could surprise with its 100 % electric technology.

Indeed, according to a revelation by CarBuzz, Ferrari has filed a patent in the USA that could revolutionize electric supercars. The patent describes the use of electric motors integrated into wheel hubs a radically different approach to what we know today.

Motors in the wheel hubs seem to be the best way to accommodate both drive units and battery packs, while retaining the feel of a mid-engined car, a feature promised by Ferrari for its future electric vehicles.

motor-electric-ferrari

At a time when many fear the end of combustion-powered supercars, Ferrari wants to demonstrate that electric supercars open up a world of new possibilities. And innovation isn't limited to engine layout. About a year ago, Ferrari also filed a patent for an innovative, sensor-rich feedback system for electric vehicles. It is designed to help drivers get better feedback from the car during sporty driving.

Like Porsche, Lamborghini and Maserati, Ferrari could have presented an electric vehicle by now, but it's clear that this is not the case. Maranello wants to ensure that its technology delivers the same sensations as combustion-powered models. It'll be a few more years before we see an all-electric Ferrari, but when it does arrive, it will be surprising.



**John Doe**  
DESIGN CHIEF

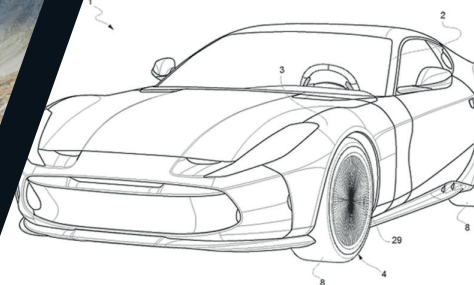

# Because a Ferrari



## **CAR STORAGE GAME CHANGER**

**AVAILABLE NOW:**

- Cat 5 hurricane-rated, climate-controlled, and fully managed.
- Social room available. Gather with friends for escorted tours of your vehicles.
- This lifestyle amenity protects your investment and enhances the value of your home or condo.
- Full-time staff on site handles your needs.
- We arrange pickup and drop-off from your residence during storms or at your convenience, and offer Naples Airport delivery and pick-up.

belongs above it all.



# **30 ABOVE**

## **Ferrari Owners**

You can now own space 30 feet above flood elevation in the heart of Naples.

for more information visit  
[www.NaplesUltimateGarages.com/30above](http://www.NaplesUltimateGarages.com/30above)  
or call and schedule a tour  
**239.682.6599.**

3101 Terrace Avenue • Naples Florida 34104

# 04



## FRANCOIS SICARD

Renowned Ferrari mechanic/race engineer/restorer  
article by Chris Rabkin

### The Man Behind the Myth:

In the grand tapestry of Ferrari history—woven with the names of legendary drivers, visionary engineers, and the unmistakable silhouette of the Cavallino Rampante—there exists a quieter thread. It is the thread of the mechanic, the race engineer, the artisan whose hands shaped performance long before computers and telemetry took the stage. Among these craftsmen, one name stands apart with a reverence usually reserved for drivers: François

Sicard. To speak with anyone who worked alongside Sicard is to hear the same refrain—precision, intuition, devotion. He was the kind of mechanic who didn't simply service a Ferrari; he



50 Years of Ferrari | Issue 144 | Forza | The Magazine About Ferrari



understood it. He listened to engines the way a conductor listens to an orchestra, attuned to the faintest discordant note. In an era when racing success depended as much on feel as on engineering, Sicard became indispensable.

Born with a natural mechanical instinct and a relentless curiosity, Sicard entered the world of motorsport at a time when the

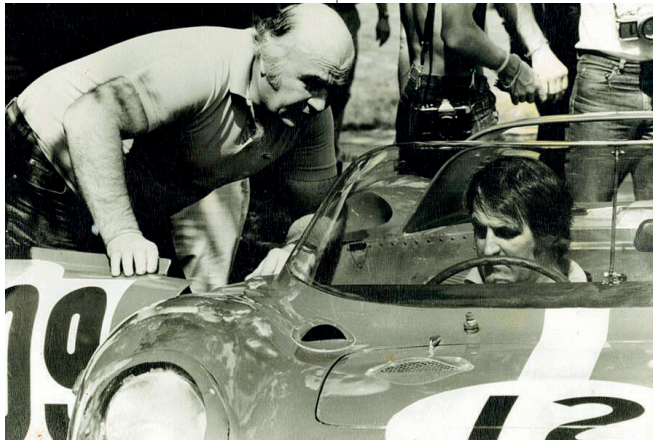

50 Years of Ferrari | Issue 144 | Forza | The Magazine  
About Ferrari

line between mechanic and race engineer was fluid. You didn't just turn wrenches—you diagnosed, interpreted, and often reinvented. His early work quickly caught the attention of teams who recognized that rare blend of technical mastery and calm under pressure. Before long, Sicard found himself working on some of the most important Ferrari competition cars of the postwar era. What set him apart was not only his skill, but his philosophy. Sicard

believed that every Ferrari had a personality—an identity shaped by its build, its history, and the drivers who pushed it to its limits. His job, as he saw it, was to bring out the best in each machine, to coax performance not through force but through understanding. This approach earned him the trust of legendary drivers who relied on his judgment as much as his craftsmanship.

### **A Craftsman of the Pre-Digital**

**Age:** Today's race engineers are armed with laptops, sensors, and

data streams. Sicard had none of that. His tools were his hands, his ears, and a lifetime of experience. He could diagnose a misfire by sound, detect imbalance by feel, and sense the health of an en-

gine through the vibrations transmitted through the chassis.

This was the golden age of me-



50 Years of Ferrari | Issue 144 | Forza | The Magazine  
About Ferrari

chanical intuition—when a mechanic's senses were as valuable as any instrument. Sicard embodied that era. He became known for his ability to prepare a car so precisely that drivers often remarked it felt "alive," responsive in a way that inspired confidence at the limit.

His reputation grew not through self-promotion, but

through results. Cars he touched ran better, lasted longer, and performed with a consistency that teams came to rely on. In the paddock, his presence was a quiet reassurance: if Sicard was on the job, the car would be ready.

### **Guardian of Ferrari's Heritage:**

As the decades progressed, Sicard's role evolved. He became not only a race engineer but a restorer—one of the few entrusted with the mechanical resurrection of historically significant Ferraris. These were not mere cars; they were artifacts of motorsport history, each with a story etched into its metal. Sicard approached

restoration with the same reverence he brought to racing: authenticity first, always.

Owners and collectors sought him out for his ability to preserve the soul of a car while returning it to its rightful glory. He understood that a Ferrari's history was as important as its performance, and he treated each restoration as a stewardship of heritage. Under his care, forgotten

machines roared back to life, ready to be shown, driven, and celebrated once more.

His work became a bridge between eras—connecting the raw, analog world of early Ferrari racing with the modern passion of today's enthusiasts. In many ways, Sicard helped ensure that the stories of these cars would not fade, but continue to inspire future generations.

### **A Historic First at the 2026 FCA Annual Meet**

This year, the Ferrari Club of America writes a new chapter in its own history. At the 2026 Annual Meet in Monticello, New York, François Sicard becomes the



<https://068magazine.com/the-prancing-horse-whisperer-fran-cois-sicard-renowned-ferrari-mechanic-race-engineer-and-more>

first mechanic ever to be honored as the event's featured personality.



<https://068magazine.com/the-prancing-horse-whisperer-fran-sicard-renowned-ferrari-mechanic-race-engineer-and-more>

In a tradition that has long spotlighted drivers, owners, and collectors, this recognition marks a profound shift—an acknowledgment of the men whose work made Ferrari's victories possible.

Sicard's selection is more than symbolic. It is a celebration of the artisans who lived in the shadows of the pit lane, whose hands coaxed performance from metal, whose intuition kept cars alive at the limit, and whose dedication shaped the legacy of the Prancing Horse.

For the Naples Chapter and for MOTORE D'ART, this moment resonates deeply. It affirms what enthusiasts have always known: that Ferrari's story is not only written on the track, but in the workshops, garages, and paddocks where craftsmen like Sicard forged the mechanical soul of the marque.

## The Legacy of a True Ferrari Maestro

François Sicard's story is not one of fame, but of mastery. He represents the essence of Ferrari's mechanical heritage: passion without ego, craftsmanship without compromise, and a lifelong devotion to the pursuit of perfection.

In honoring him at Monticello, the Ferrari Club of America honors the spirit of Ferrari itself.

### 1940s–1950s — Early Mechanical Roots

- Develops a natural instinct for machinery and engines
- Begins working in motorsport during the postwar boom
- Quickly recognized for precision and calm under pressure

### 1960s — Rise in European Racing Circles

- Joins teams preparing competition cars for endurance and GT racing
- Builds a reputation for diagnosing issues by sound and feel
- Gains the trust of drivers who rely on his intuition

### 1970s — Work with Ferrari Competition Cars

- Becomes involved with significant Ferrari race machinery
- Known for preparing cars that feel "alive" and responsive
- Establishes himself as a go-to mechanic for high-stakes events

### 1980s–1990s — Master Restorer

- Expands into restoration of historically important Ferraris
- Prioritizes authenticity and mechanical integrity
- Helps preserve rare competition cars for collectors and museums

### 2000s–2020s — Guardian of Ferrari Heritage

- Continues to restore, maintain, and advise on iconic Ferraris
- Becomes a respected figure in the global Ferrari community
- His craftsmanship influences a new generation of restorers

### 2026 — A Historic First

- Named the first mechanic ever featured at the Ferrari Club of America Annual Meet
- Honored at the 2026 Monticello, New York Meet
- Recognized for a lifetime of mechanical mastery and devotion to the marque



# PROVIDENT

J E W E L R Y

Full Page

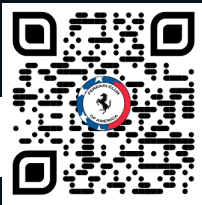
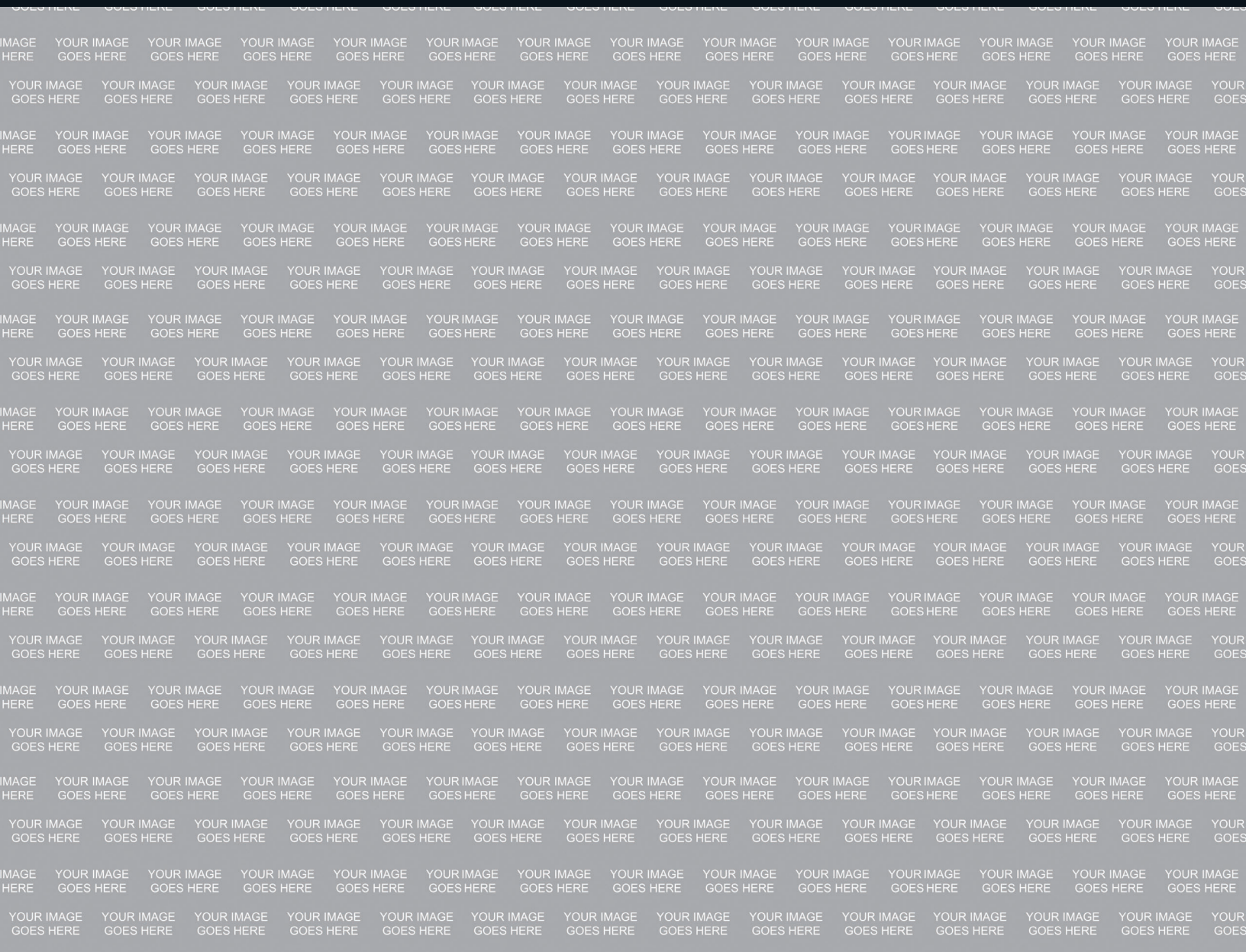

VISIT THE NAPLES FERRARI CLUB



OFFICIAL FERRARI DEALER FERRARI OF NAPLES

BANK OF AMERICA PRIVATE BANK



CHAPTER DETAILING PARTNER OLYMPIC AUTO SHINE



30

ABOVE